

4/6/18



Polymer Infiltration Device for Eglin Air Force Base

Michael Haimowitz, James Jenkins, Catherine Kent, Emily Stern

Team01

FAMU-FSU College of Engineering 2525 Pottsdamer St. Tallahassee, FL. 32310



Abstract

Our team's project centers on creating a device to fill a lattice structure with silicone, a two-part, rubbery chemical. Our sponsor is Eglin Air Force Research Laboratory (AFRL). AFRL is currently studying the use of lattice structures inside of warhead payloads. This device will assist in furthering their research by filling the lattices with even density. Currently, AFRL hand pours the silicone into the lattice structures and allows it to harden. This method causes air bubbles to get trapped inside of the hardened silicone which causes major issues in the application such as early and uneven detonation of the warheads. Our device can package the silicone into the structure with minimal air bubbles (less than 1% per volume). Our device fills square and cylindrical lattices with various lattice patterns. The lattices vary in length and width from 2in x 2in to 3in x 3in for the cubes and from 1in to 3in radius cylinders. AFRL cannot remove material from the structures once the silicone is inside. Due to this obstacle, the silicone must protrude no further than 0.001 inches from the surface of the lattices.



Acknowledgement

We would like to thank our sponsor, the Air Force Research Laboratory (AFRL), Munitions Directorate. We would especially like to thank Dr. Philip Flater, our liaison from AFRL. Without the funding and expert guidance provided by AFRL and Dr. Flater, this project could not occur.

Thank you to our advisers Dr. Eric Hellstrom and Dr. Shayne McConomy from the FAMU-FSU College of Engineering. Dr. Hellstrom and Dr. McConomy provided us with the guidance necessary for our project from beginning to end. We appreciate all of the advice and help that both Dr. Hellstrom and Dr. McConomy have given us.

Thank you to all of the people who have help provide us with the materials and tools to help us create our design and prototype. This includes the FAMU-FSU College of Engineering and Eglin Air Force Base. The FAMU-FSU College of Engineering provided much needed tools such as 3D-printers that we used to create models to test our prototype with. Eglin Air Force Base provided our initial 3D-printed lattices.



Table of Contents

Abstract	ii
Acknowledgement	iii
List of Tables	vii
List of Figures	viii
Notation.....	i
Chapter One: EML 4551C	1
1.1 Project Scope.....	1
1.1.1 Project Description.....	1
1.1.2 Key Project Goals	1
1.1.3 Market	1
1.1.4 Assumptions.....	1
1.1.5 Stakeholders.....	2
1.2 Customer Needs	2
1.3 Functional Decomposition	5
1.4 Target Summary.....	5
1.5 Concept Generation	7
System 1 (Degas Silicone).....	7



System 2 (Fill Lattice)	9
System 3 (Isolate Lattice)	10
1.6 Concept Selection	13
1.6.1 Pugh Matrix	13
1.6.2 Decision Matrix	15
1.6.3 Final Selection	20
1.8 Spring Project Plan	20
Chapter Two: EML 4552C	22
2.1 Spring Plan.....	22
Project Plan.....	22
Build Plan.....	23
Appendices.....	24
Appendix A: Code of Conduct	25
A.1 Mission Statement.....	25
A.2 Roles.....	26
A.2.1 Team Leader - Mike Haimowitz.....	26
A.2.2 Lead ME/Research Coordinator – Catherine Kent	26
A.2.3 Lead Technologist – Emily Stern.....	26
Team01	v



A.2.4 Lead of CAD/Simulation – James Jenkins	27
A.2.5 Financial Adviser –	27
A.2.6 All Team Members	27
A.2.7 Organizational Chart	28
A.3 Communication	29
A.4 Team Dynamics	30
A.4.1 Ethics	30
A.4.2 Dress Code	30
A.4.3 Weekly and Biweekly Tasks	30
A.4.4 Decision Making	31
A.4.5 Conflict Resolution	32
A.5 Statement of Understanding	33
Appendix B: Functional Decomposition	2
Appendix C: Target Catalog	3
References	5



List of Tables

Table 1 Customer Needs derivation table.....	4
Table 2 Pugh Matrix - Degas Silicone.....	13
Table 3 Pugh Matrix – Fill Lattice.....	14
Table 4 Pugh Matrix – Isolate Lattice.....	15
Table 5 Decision Matrix – Degas Silicone	16
Table 6 Decision Matrix – Fill Lattice.....	18
Table 7 Decision Matrix – Isolate Lattice.....	19
Table 8 Team Role Organizational Chart.....	28



List of Figures

Figure 1 Three lattice designs (a) Cylinder (b) Large Cube (c) Small Cube.	2
Figure 2 Vacuum Pump used to evacuate air from a chamber or bag.	8
Figure 3 Plunger and Molding Chamber for isolating a lattice.	11
Figure 4 Jig used to contain lattice with matching geometry.	12
Figure 5 Selected Design	20
Figure 6 Gantt Chart	22



Notation

EAFBRL Eglin Air Force Base Research Lab



Chapter One: EML 4551C

1.1 Project Scope

Design and build a prototype machine for infiltrating open-cell lattice structures with Sylgard 184 silicone.

1.1.1 Project Description

The objective of this project is to create a device that fills lattice structures with Sylgard 184 silicone without any air voids. The device must accommodate for variable shapes, sizes, and cavity structures. The team must validate the effectiveness of the prototype in completely filling provided lattice structures without any voids, and deliver the final prototype to AFRL.

1.1.2 Key Project Goals

The prototype must not require unreasonable ancillary equipment; one example of a reasonable ancillary device would be an electric vacuum pump. The device must be able to fill the cavities in the lattice structure with a maximum porosity of one percent. The device must be compatible with both plastic and metal printed lattices. Device must be capable of accommodating lattices of varying height.

1.1.3 Market

The primary markets for polymer infiltration of cellular lattices are the military-industrial complex, aerospace, and automotive industries where high strength/low density materials are desired.

1.1.4 Assumptions

The project scope will constrain the lattice geometries to not vary beyond the three shapes provided, see Figure 1.

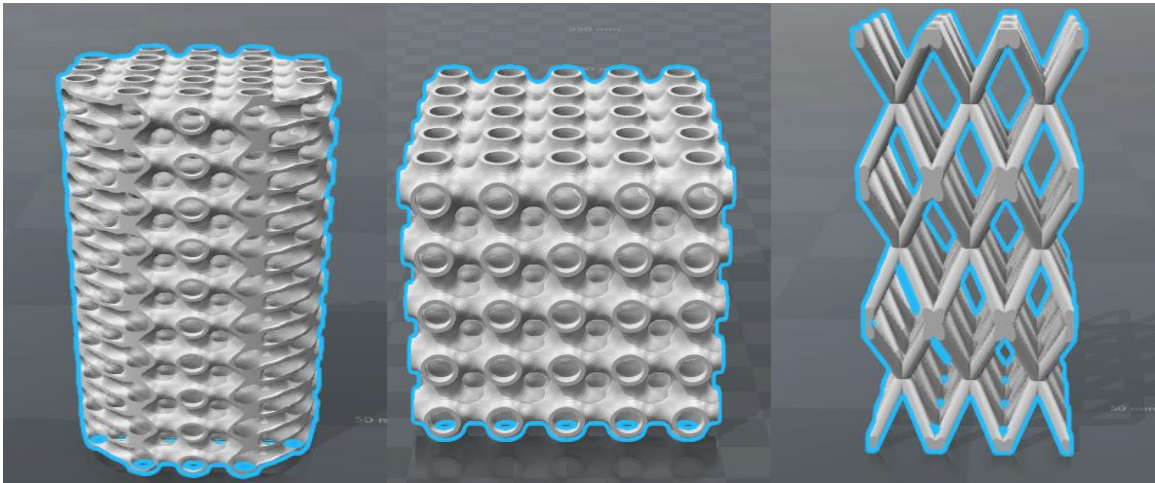

Figure 1 Three lattice designs (a) Cylinder (b) Large Cube (c) Small Cube.

The polymer used to fill these lattices will be Sylgard 184 Silicone manufactured by Dow/Corning. The silicone is assumed to be a homogenous mixture, and additional interstitial solids will not be added to the mixture.

1.1.5 Stakeholders

The primary beneficiary of the Polymer Infiltration project is the United States Air Force with Dr. Philip Flater as its representative to the FAMU-FSU College of Engineering and the design team. The FAMU-FSU College of Engineering staff providing insight and funding are Dr. Chiang Shih, Dr. Shayne McConomy and the project advisor is Dr. Eric Hellstrom.

1.2 Customer Needs

The customer needs were extracted from the initial project description that our sponsor provided us. Key customer needs were described within the project description section. (Flater, 2017). Customer needs were also gathered through conference with the sponsor. Table 1 below displays the information that was provided to us through the project definition or through



conference with the sponsor, the customer response and the interpreted need the team will need to apply for the project.



Table 1 *Customer Needs derivation table*

Information Provided	Verbalized Need	Interpreted Need
“Ensure uniform distribution of polymer infill while eliminating air voids/porosity for a variety of bulk shapes.”	Lattice must be infiltrated with silicone without voids	Fills lattices with specified polymer
		Fills lattice without porosity
	Can fill multiple lattice geometries	Fills small cube, large cube, and cylindrical lattices
		Specimens unconstrained in height
“Validate infiltration effectiveness”		Specimens constrained by length and width
“Be compatible with AFRL processes and equipment.”		Ensure a working device
“Provide user and safety manuals.”		Use standardized equipment
		Use standardized parts
		Provide guidelines for safe and effective device operation

The needs expressed by the sponsor and in the project brief were broken down to understand what the customer needs. The team then transformed the customer needs into technical statements. The technical translations of the customer needs were adopted in order to eliminate miscommunication between the team and the sponsor. This is shown in Table 1, where the sponsor expressed that multiple geometries should be able to be filled. The team was able to clarify that the device must be suitable for a small cube, a large cube, and a cylindrical lattice.



Some more technical aspects were established which included that the specimen is constrained in length and width but has a variable height. In addition, some of the sponsor's information was decoupled to identify each need for the project. In the project definition, our sponsor specified that the device must "ensure uniform distribution of polymer infill while eliminating air voids/porosity for a variety of bulk shapes." This was broken up into two separate needs: the lattice being infiltrated with silicone without voids and the device should be able to accommodate different geometries. (Flater, 2017)

1.3 Functional Decomposition

- Contain fluid
- Purge fluid and lattice of air
- Isolate lattice
- Transfer fluid
- Fill lattice

1.4 Target Summary

The top priority for this project is minimizing porosity (<1%). This target was stated by the Project Liaison, Dr. Phillip Flater. Porosity is the top priority due to the application of the products the device will create. The final device will use explosives in place of Sylgard and fill lattices to be placed inside of ammunitions. Having any voids inside the explosive structure can cause an uneven load distribution resulting in early structural failure and even premature explosions. Air voids will also cause the ammunition to experience hot spots once detonated. Hot spots can cause an improper explosion and potentially cause unintended damage.



To measure the porosity target, two methods will be used. The first method is via serial sectioning. This is a destructive process in which the filled lattice will be cut in small slices and the number of voids will be calculated from sight. The findings will be reported via a porosity density ratio. The ratio will be calculated by comparing the expected mass to the actual mass of the filled lattice. The expected mass will be calculated using the weight of the empty lattice, the volume of the empty lattice, and the density of the Sylgard. This method will allow for non-destructive porosity measurements which will be reported in the same manner as the serial sectioning.

Other targets that will need to be met will include keeping the working pressure and time within limits set by the material and equipment. The working pressure needs to be at least 28 mmHg (0.54 psi) to completely degas the silicone. While this is a relatively low pressure, it will need to be verified that a vacuum pump that can achieve this can be acquired and the pressure will not interfere with other sub-processes of the device. This pressure was determined from background research (Smooth-On, 2017). The number will be verified empirically using a vacuum with a pressure gage. The working time of silicone is limited by the pot time. Pot time is defined as the amount time a material takes to double in viscosity (Dow Corning, 2004). After the pot time for Sylgard 184 (1.5 hours) (Dow Corning, 2004) is reached, the material will become harder to work with and may no longer be able to be manipulated for insertion or movement. Before the pot time expires, the device will need to degas the silicone and fill the lattice. The time for filling the lattice must be short enough to allow time for the other steps of the process (transportation of the silicone, degassing, etc.) and allow for extra time to rid the lattice of any extra voids that may have occurred during filling. However, the fill time must be long enough to ensure excessive bubbles are not introduced to the structure. Degassing of the silicone must also occur before the allotted pot time. The degassing time will need to be



determined empirically to reach optimal air purged from the silicone which is determined by visual inspection.

The steps of the process should be as simple and as few as possible. This will ensure that the user of the device will be able to properly use it with no equipment or user failures. The number of goal steps will be limited by the complexity of the final chosen design.

1.5 Concept Generation

System 1 (Degas Silicone)

The client's most important stated need is a lack of porosity. Because of the relatively high viscosity of silicone it is very common for air to be trapped within it. This will be one of the greatest sources of air throughout the process, so it is necessary that it be removed in order to avoid porosity.

Concept 1 (Vacuum)

Concept 1 removes air from the medium by placing it in a vacuum chamber. This is a very common method in-industry, and very simple. By removing the ambient air, the silicone will expand up to 400% as the bubbles are pulled up to the top. At a critical point, the silicone will contract after enough air is removed from the mixture.

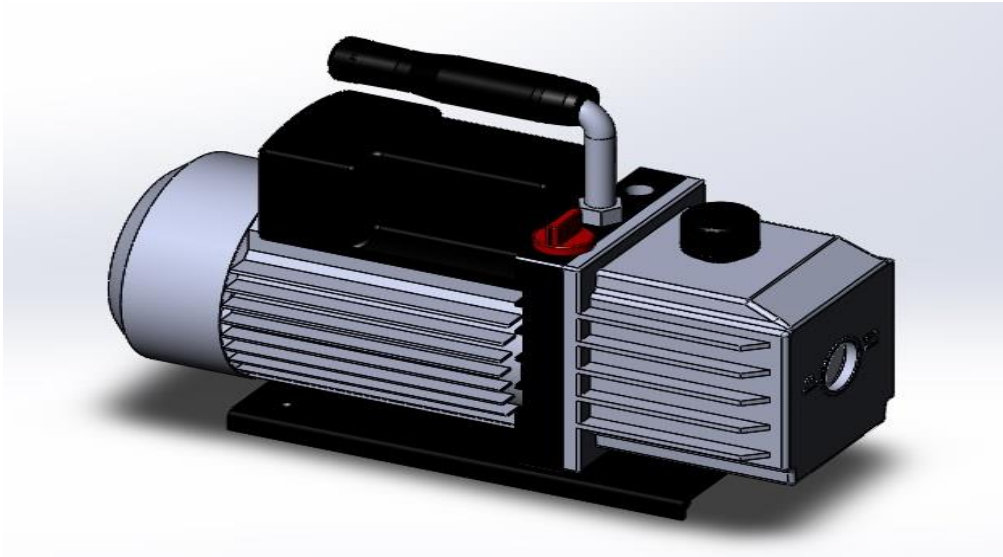

Figure 2 Vacuum Pump used to evacuate air from a chamber or bag.

Pros: This method can accommodate a large amount of silicone. In addition the vacuum pump can be utilized elsewhere in the design, requiring less hardware overall.

Cons: A large vacuum volume is required in order to accommodate up to 400% expansion of the silicone.

Concept 2 (Centrifuge)

Concept 2 utilized the centrifugal force to isolate the silicone from the entrapped air. This is done by increasing the effective force of gravity within the silicone.

Pros: Can be done very quickly (~2 minutes) and does not cause volume expansion.

Cons: Can only accommodate small amounts of silicone at a time (~10mL).

Concept 3 (Vibration)

Concept 2 utilizes vibration to motivate the bubbles to the top.

Pros: Does not cause volume expansion.

Cons: Requires time to allow the bubbles to rise to the surface.



System 2 (Fill Lattice)

System 2 is a method to fill the lattice without any air. It is vital that air be removed from the lattice in order to decrease porosity.

Concept 1 (Vacuum)

Concept 1 utilized a vacuum to remove all of the air within a chamber that houses the lattice.

Pros: This completely removes the possibility of air being trapped within the lattice, because there is no air inside the lattice to trap.

Cons: This requires a pressurized chamber.

Concept 2 (Fill from top)

Concept 2 removes the air from the lattice by displacement with silicone. The silicone flows through the lattice from the top to the bottom.

Pros: Can be achieved very simply, in open air, by pouring the silicone directly onto the lattice. Can direct the silicone to where it is needed.

Cons: Can easily trap bubbles and air within the lattice. Can easily introduce air into previously degassed silicone due to turbulent flow.

Concept 3 (Fill from bottom)

Concept 3 removes the air from the lattice by displacement with the silicone. The silicone flows through the lattice from the bottom to the top.

Pros: More difficult to accidentally trap air, because the silicone is displacing the air from the bottom.

Cons: Must be done slowly. If done too fast, the flow through the lattice could be uneven and trap air within the lattice.



Concept 4 (Weight Scale)

Concept 4 uses a weight scale to directly measure and control the exact amount of silicone that is introduced to the lattice. Scale would also be used to predict the final weight of the lattice, so we know when we have poured enough silicone to replace all the air that was originally in the lattice.

Pros: Using a scale will help to measure how much silicone is needed for the lattice being filled, reducing the amount of silicone left over and wasted.

Cons: Measuring out the amount of silicone needed to fill the lattice will require pulling vacuum on the chamber multiple times in between steps.

Concept 5 (Vibration)

Concept 4 uses a vibrating table to remove air from the lattice once the silicone has been introduced to the lattice.

Pros: Using vibration causes the coefficient of friction in the silicone to be reduced, allowing air bubbles to rise with less resistance.

Cons: Air bubbles that are trapped on the lattice structure may remain stuck while under vibration.

System 3 (Isolate Lattice)

These methods will insure that the lattice is isolated, so that the silicone being introduced is only able to flow to the lattice and can't overflow or be wasted.

Concept 1 (Plunger and Molding Chamber)

The vacuum purges the molding chamber of air before the silicone is introduced to the system and continues to pull vacuum drawing the silicone into the chamber and beyond to the catch can.

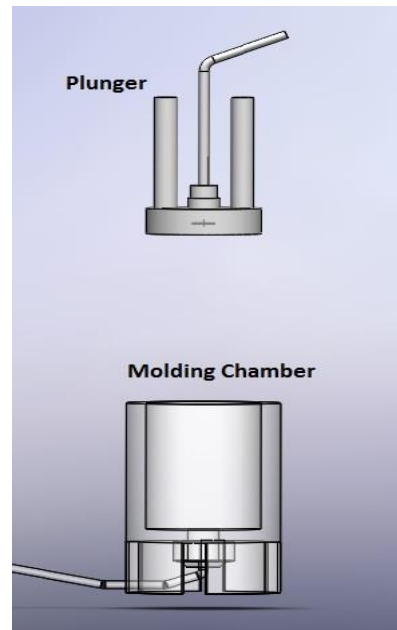

Figure 3 Plunger and Molding Chamber for isolating a lattice.

Pros: Plunger allows for quick adjustments for lattices of different heights and enforces a seal using an O-ring forced against the molding chamber wall using a chuck mechanism. The molding chamber provides a rigid casting chamber for the lattice for vacuum to be maintained and the lattice restrained in the X and Y axes.

Cons: Molding chamber does not allow for varying geometries in the X and Y plane. The plunger O-ring could create an imperfect seal disrupting the vacuum environment.

Concept 2 (Jig)

Concept 2 is a container used to hold the lattice in place that is designed for a particular lattice shape and size.

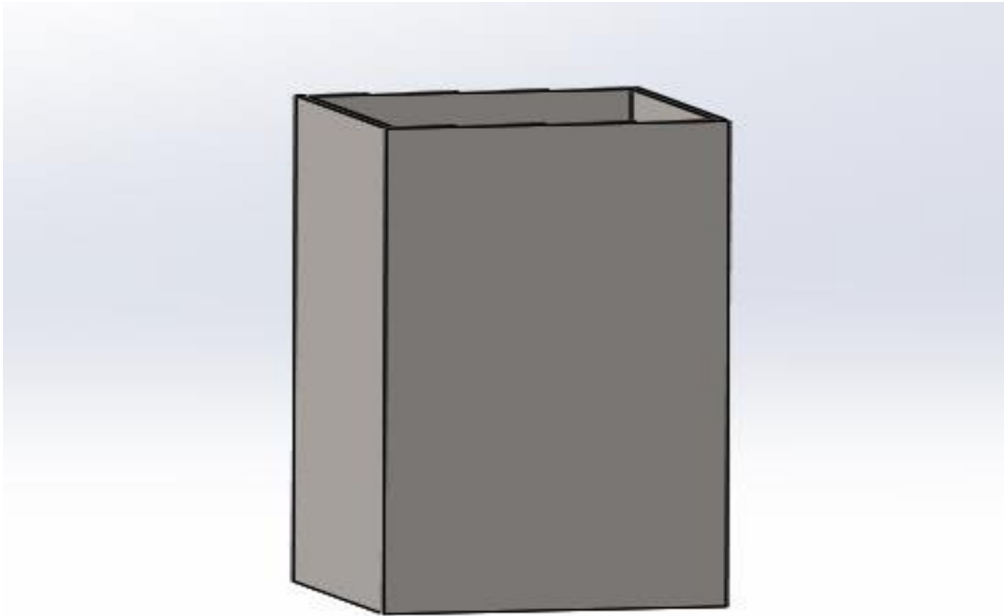

Figure 4 Jig used to contain lattice with matching geometry.

Pros: A jig can be tailored to control the tolerances of the final lattice, and allows for easy mobility of the lattice during the infiltration process.

Cons: Requires a specific jig to be manufactured for each variation of lattices

Concept 3 (Vacuum Bag)

Concept 3 utilizes a bag as the vacuum chamber instead of having to pull vacuum on a larger volume, this allows for a quicker vacuum to be pulled.

Pros: This method can produce glossy finishes, and can reduce the amount of volatiles (ex. water, ethyl acetate) during the curing process, which would lead to voids.

Cons: May cause indentations where the bagging is pulled into the lattice, which would cause the lattice to not be filled completely. Compacts the area in which the silicone will be traveling, which could cause difficulty in controlling where the silicone flows.



1.6 Concept Selection

In order to select our final concept, a Decision Matrix and Pugh Chart were constructed in order to compare our designs for each system. The Pugh Chart was used to compare each concept directly to the other concepts, using an arbitrarily chosen datum. The Decision Matrix helped to establish a hierarchy of our evaluation criteria to account for the most important targets and customer needs. Both techniques were used to evaluate which design should be selected.

1.6.1 Pugh Matrix

For degassing the silicone, the use of a centrifuge and a vibration table is compared to the current industry standard of vacuum degassing. Each technology was compared on the basis of porosity, allowable fluid volume, degassing time, and cost. Porosity is the measure of how effective the concept is at removing gas pores from the Silicone. The allowable fluid volume is the volumetric amount of silicone that can be degassed in one cycle. Lastly, the degassing time is the amount of time the concept takes to remove the gas. When completed, the Pugh matrix determined that neither the centrifuge nor the vibration table provided a benefit over the vacuum, as seen in Table 2.

Table 2 *Pugh Matrix - Degas Silicone*

Degas Silicone		Concepts		
Criteria		Vacuum	Centrifuge	Vibration
Porosity			0	-1
Allowable Fluid Volume		Datum	-1	0
Degas Time			-1	-1
	Pluses	0	0	0
	Minuses	0	2	2



The second element of the functional decomposition to be investigated is filling the lattice with the judging criteria set as the porosity, geometric compatibility and total working time. The porosity in this test will reflect the concepts ability to abstain from creating or maintaining voids while filling the lattice with silicone. Geometric compatibility refers to the concepts ability to be utilized with different shapes without modification. Finally, the total working time is the metric of how long it takes the concept to fully fill the lattice with silicone. A vibration table under vacuum was used as our datum to be evaluated against filling from the bottom under vacuum, filling from the top under vacuum and injection from the top. The Pugh matrix ranked filling from the bottom with vacuum as the most effective concept at satisfying customer needs.

Table 3 *Pugh Matrix – Fill Lattice*

Fill Lattice		Concepts			
Criteria		Vibration with Vacuum	Fill from Bottom with vacuum	Inject from Top	Pour from Top with Vacuum
Porosity		Datum	1	-1	-1
Geometric Compatibility			0	0	0
Total Working Time			1	0	-1
	Pluses	0	2	0	0
	Minuses	0	0	1	2

For the final matrix, the concepts for isolating the lattice are compared with the vacuum bag being used as the baseline. In this test, geometric compatibility measures the concepts ability to isolate lattices of different shapes without modification. The total working time is the time the concept takes to accept the lattice and be ready to rock. The surface tolerance refers to the



surface texture as well as how far from the surface of the lattice the silicone is allowed to set. When compared to the jig and the plunger, the vacuum bag has the greatest ratio of benefits to detriments.

Table 4 *Pugh Matrix – Isolate Lattice*

Isolate Lattice		Concepts		
Criteria		Vacuum Bag	Jig	Plunger
Geometric Compatibility		Datum	-1	-1
Total Working Time			-1	-1
Surface Tolerance			1	1
	Pluses	0	1	1
	Minuses	0	2	2

1.6.2 Decision Matrix

The first system that concepts were generated for was to degas the Silicone. The criteria that was established for the decision matrix was how well the design eliminates porosity, the allowable fluid volume, the time it takes to degas the Silicone, and cost. Each of these criteria were ranked based on their importance on a scale of 1 to 5, five being most favorable. Porosity was weighted the highest since our main objective is to eliminate all air voids. Allowable fluid volume was ranked the lowest because the pot life is long enough to accommodate for most methods and it does not matter if there needs to be multiple batches to degas. After evaluating each concept based on the specified criteria, the vacuum was found to be the best option which was followed by vibration and then centrifuge. The main reasons the vacuum was found to be the best option was its ability to create low porosity which is high priority for our design. The



vacuum also ranked highest for degas time and had moderately good ranking values for cost and allowable fluid volume. The centrifuge is also ranked high for porosity and degas time but was ranked lower for the other criteria which is why the vacuum concept outranked it. Even though vibration was ranked high for allowable fluid volume since a vibration table can account for large volumes, and also cost efficient, vibration is not good for creating low porosity and has a slow degas time which was weighted more heavily.

Table 5 *Decision Matrix – Degas Silicone*

Degas Silicone							
		Concepts					
		Vacuum		Centrifuge		Vibration	
Criteria	Weight	Rank	Score	Rank	Score	Rank	Score
Low Porosity	5	9	45	9	45	7	35
Allowable Fluid Volume	2	7	14	3	6	8	16
Degas Time	4	8	32	7	28	6	24
Low Cost	3	6	18	5	15	8	24
	Total	109		94		99	

The second system of our design deals with replacing the air inside the lattice with silicone, which can be seen in Table 6. Three different concepts were compared based on their ability to fill the lattice quickly, have low porosity, be cost effective, and be geometrically compatible. The criteria were also ranked on a scale of 1 to 5. Porosity was given a five due to it



being the main target of our design. The remaining criteria of fill time, low cost, and geometric compatibility were ranked 4, 3, and 2 respectively. After completing the Decision Matrix the highest ranked concept for System 2 was “Fill from Top with Vacuum”. Fill from Top with Vacuum received the highest ranking, because the use of a vacuum is expected to remove all the air that could potentially be retained as voids. The fill time for this concept is not known but is expected to only span a few minutes. This concept however could require additional fabrication of components to accommodate varying lattice shapes, which could increase the initial cost of the design. The lowest weight criteria was Geometric Compatibility. This criteria was weighted lowest, but the fill from bottom concept still is effective because it is not dependent on the geometry of the lattice.



Table 6 Decision Matrix – Fill Lattice

Fill Lattice									
		Concepts							
		Vibration/ Vacuum		Bottom Fill/Vacuum		Top Fill/Vacuum		Top Fill	
Criteria	Weight	Rank	Weight	Rank	Weight	Rank	Weight	Rank	Weight
Low Porosity	5	8	40	9	45	8	40	8	40
Geometric Compatibility	2	8	16	9	18	9	18	9	18
Fill Time	4	5	20	9	36	8	32	4	16
Low Cost	3	8	24	6	18	6	18	7	21
	Total	100		117		108		95	

The third system of our design is focused on the isolation of the lattice itself, and the concepts ability facilitate a proper fill, which can be seen in Table 7. The criteria used to compare these concepts were geometrically compatible, surface tolerance, unconstrained in height, constrained in length and width, and low cost. Three of these criteria (surface tolerance, unconstrained in height, and constrained in length and width) are extremely important and they must be met by the design concept. These criteria all received 5's which ultimately weighed heavily on each concepts ranking. The highest ranking concept was the "Jig with a Weight Scale", this was largely due to the concepts open jig design that adequately constrains the lattice in length and width while allowing it to vary in height. These constraints will allow for more precision in controlling the tolerances of the silicone protruding from the lattices surface. To allow for a variety of lattice geometries, jigs would need to be fabricated to accommodate the



respective lattice shape. This makes the concept initially less adaptable, and would increase the initial costs. However once fabricated the jigs would be reusable and save money, and allow for quick preparation for future uses. The weighted scale portion of the concept would control the amount of silicone being prepared and reduce excess, which will further reduces costs.

Table 7 Decision Matrix – Isolate Lattice

Isolate Lattice							
		Concepts					
		Vacuum Bag		Jig/Weight Scale		Jig/Plunger	
Criteria	Weight	Rank	Score	Rank	Score	Rank	Score
Geometric Compatibility	3	8	24	4	12	4	12
Surface Tolerance	5	6	30	9	45	9	45
Height unconstrained	5	9	45	10	50	9	45
Length/Width constrained	5	9	45	10	50	9	45
Low Cost	2	5	10	7	14	6	12
	Total	154		171		159	

1.6.3 Final Selection

Utilizing the Decision matrix and the Pugh matrix as well as our own collective reasoning, the concepts for each aspect of the function decomposition were chosen. The Decision matrix was found to be more effective than the Pugh due to the lack of a weighting system, as porosity is of greater importance to the project than the other constraints.

The best concept to degas the silicone before filling the lattice is the vacuum. It was found that the vacuum would be the most effective method for dealing with the amount of silicone needed and while staying within our budget. To best fill the lattice with minimal porosity, filling from the bottom with vacuum will be used. This concept is simple, cost effective and has a lesser chance of porosity than filling from the top. The jig was chosen as the concept for isolating the lattice. It is the best option for balancing cost and surface tolerance.



Figure 5 Selected Design

1.8 Spring Project Plan



Chapter Two: EML 4552C

2.1 Spring Plan

Project Plan.

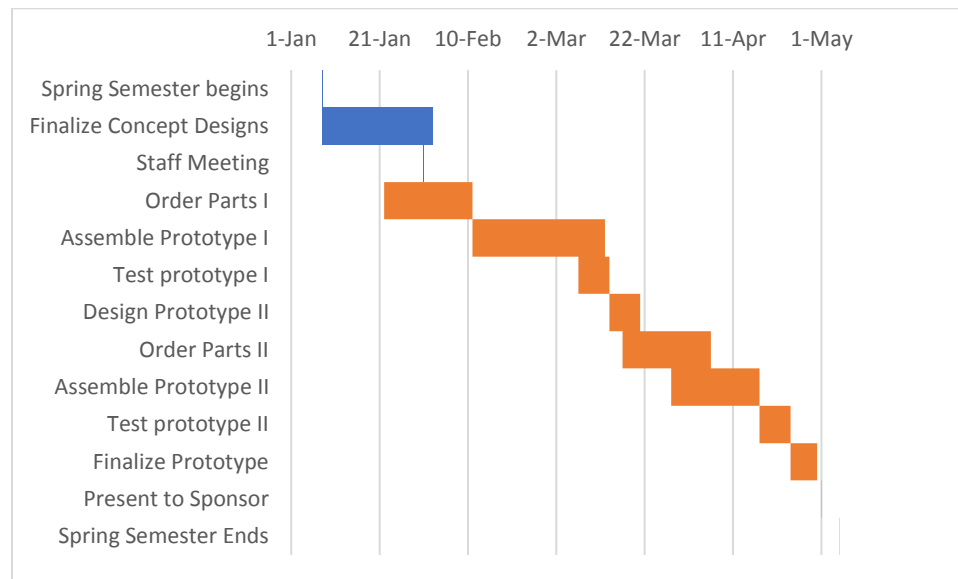

Figure 6 Gantt Chart

The first two weeks of spring semester will be spent choosing proven technologies for the concepts chosen in concept selection. After completion and review of designs created using CAD, the parts to build Prototype I will be ordered. It is expected that the parts ordered will be received in the span of three weeks. The assembly phase of Prototype I will begin as soon as the first parts are received and is projected to take around a month. After, the prototype will be tested for efficacy over the span of a week.

If our sponsor's goals are not met with Prototype I, the design of Prototype II will commence. This process will ideally take around 7 days with the parts required to make the initial changes being ordered in the first 3 days. The same process for Prototype I will be



followed with Prototype II, although the assembly time is projected to be shorter given the experience gained and progress made while assembling Prototype I. Prototype II will go through the same tests for effectiveness as prototype was subjected to. If there exists an imperfection, the team will have one week to finalize the product before it is presented to Dr. Flatter at Eglin Airforce Base.

As of January 31st, the project is more the most part proceeding as planned. The finalization of the project design and the ordering of the necessary parts are taking more time than anticipated due to construction restrictions from our vacuum chamber fabricator and budget allocation confusion respectively. Moving forward, potential bottlenecks do exist in completing the ordering of parts and assembly for the first prototype as the experience and information gained in the testing and performance of prototype I is crucial for moving forward to prototype II. Team 01 is confident that they will reach the finish line under budget and ahead of schedule.

Build Plan.



Appendices



Appendix A: Code of Conduct

A.1 Mission Statement

Team 1 is committed to ensuring a positive work environment that supports professionalism, integrity, respect, and trust to all members and persons. Every member of this team will contribute a full effort to the creation and maintenance of such an environment in order to bring out the best in all of us as well as this project.



A.2 Roles

Each member is delegated a team role based on their specific experiences and skill sets, and is the primary guarantor for the work shown in Table 1 and therein:

A.2.1 Team Leader - Mike Haimowitz

Manages the team as a whole; develops a plan and timeline for the project, delegates tasks among group member according to their skill sets; finalizes all documents and provides input on other positions where needed. The Team leader must promote teamwork and have the team's best interest as priority. The team leader takes the lead in organizing, planning, and setting up team meetings. In addition, the team leader is responsible for keeping a record of all group correspondence and meeting minutes.

A.2.2 Lead ME/Research Coordinator – Catherine Kent

Takes charge of the mechanical design aspects of the project. Lead ME is responsible for knowing details of the design, and presenting the options for each aspect to the team for the decision process. Collects all documentation of all iterations pertaining to the project for records.

A.2.3 Lead Technologist – Emily Stern

In charge of creating the website for the project in order to help advisors and sponsors keep track of the progress of the design. It is crucial the website is kept up to date and includes current versions of the design. The website should include but not limited to: Team Information, Deliverables, and Project Scope.



A.2.4 Lead of CAD/Simulation – James Jenkins

Manages the simulation and CAD modeling aspects of the team’s design, including but not limited to parts, assemblies, and drawings. The Lead of CAD/Simulation acts as the liaison between team and the Sponsor Liaison. The Lead of CAD/Simulation must create, compile, and organize the modeling and simulation aspects of the project.

A.2.5 Financial Adviser –

Manages the budget and maintains a record of all credits and debits to project account. Any product or expenditure requests must be presented to the advisor, whom is then responsible for reviewing and the analysis of equivalent/alternate solutions. They then relay that information to the team. If the expenditure request is granted, they order the selection. A record of these analyses and budget adjustments must be kept. Must collect all documentation pertaining to the financial aspect of this project.

A.2.6 All Team Members

- Work on certain tasks of the project
- Buys into the project goals and success
- Delivers on commitments
- Adopt team spirit
- Listen and contribute constructively (feedback)
- Be effective in trying to get message across
- Be open minded to others ideas
- Respect others roles and ideas



A.2.7 Organizational Chart

Table 8 *Team Role Organizational Chart*

	Team Leader	Lead ME/Research Coordinator	Lead Technologist	Lead of CAD/Simulation	Financial Advisor
Michael Haimowitz	X				
Robert Hutchinson					X
James Jenkins				X	
Catherine Kent		X			
Emily Stern			X		



A.3 Communication

The main form of communication will be over phone, through the GroupMe app. Google hangouts can also be used for informal meetings. Email will be a secondary form of communication for matters that are not time-sensitive as well as Meeting Minutes Summaries. The main form of file transfer (i.e. files and presentations) will be through Google Drive. Each group member must have a working Gmail for the purposes of communication and file transference. Members must check their emails as regularly as possible to check for important information and updates from the group. It is also important for each member to check their emails frequently for pertinent information from the Sponsor Liaison.

Any team member that cannot attend a meeting must notify group members 6 hours in advance and are responsible for uploading and providing any information that was assigned to them for that meeting. Reason for absence will be appreciated but not required if personal. Repeated absences in violation with this agreement will not be tolerated.



A.4 Team Dynamics

Team 1 will function as a cohesive unit striving to enable one another to feel open to provide individual insight into any given obstacle encountered without ridicule or disrespect. Team members are expected to feel welcome to ask for assistance on work that surpasses their capabilities. Those who feel they are not being included are to bring complains to the attention of the entire team as to remedy issues wholly and quickly. Team members are encouraged to govern their actions with logic and reason, rather than emotions and feelings.

A.4.1 Ethics

Team members are required to be familiar with the NSPE Engineering Code of ethics as they are responsible for their obligations to the public, the client, the employer, and the profession. There will be stringent following of the NSPE Engineering Code of Ethics.

A.4.2 Dress Code

Team meetings will be held in casual attire. Sponsor meetings and group presentations will be business casual to formal as decided by the team per the event.

A.4.3 Weekly and Biweekly Tasks

Team members will participate in all meetings with the sponsor, adviser, and instructor. During said times, ideas, project progress, budget, conflicts, timelines and due dates will be discussed. In addition, tasks will be delegated to team members during these meetings. Repeat absences will not be tolerated.



A.4.4 Decision Making

Decision making is conducted by consensus and a majority of the team members. A meeting of 3/5 members is to be considered quorum. Each team member is to be knowledgeable of the logical, moral, and ethical reasons for all team decisions reached. Dissenting opinions are encouraged, to be evaluated as a team with their moral and ethical implications to be taken into consideration. Individuals with conflicts of interest are allowed to contribute to discussion though are not to participate in the decision-making processes and are not required to specify said conflict. Each team member is to act ethically and for the interests of the team and the goals of the project. Achieving the goal of the project will be the top priority for each group member. Below are the steps to be followed for each decision-making process:

- Problem Definition – Define the problem and understand it. Discuss among the group.
- Tentative Solutions – Brainstorms possible solutions. Discuss among group most plausible.
- Data/History Gathering and Analyses – Gather necessary data required for implementing Tentative Solution. Re-evaluate Tentative Solution for plausibility and effectiveness.
- Design – Design the Tentative Solution product and construct it. Re-evaluate for plausibility and effectiveness.
- Test and Simulation/Observation – Test design for Tentative Solution and gather data. Re-evaluate for plausibility and effectiveness.
- Final Evaluation – Evaluate the testing phase and determine its level of success. Decide if design can be improved and if time/budget allows for it.



A.4.5 Conflict Resolution





In the event of discord amongst team members the following steps shall be respectfully employed:

- Communication of points of interest from both parties which may include demonstration of active listening by both parties through paraphrasing or other tool acknowledging clear understanding.
- Administration of a vote, if needed, favoring majority rule.
- Team Leader intervention.
- TA intervention.
- Instructor intervention.

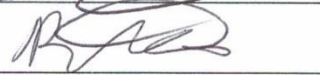

A.5 Statement of Understanding

By signing this document the members of Team 1 agree on all of the above and will abide by the Code of Conduct set forth by this group.

<u>Name</u>	<u>Signature</u>	<u>Date</u>
Catherine Kent		09-20-17
Emily Stern		9/20/17
Mike Haimowitz		9/20/17
Robert Huthinson		9/20-17
James Jenkins		9-20-17



Appendix B: Functional Decomposition



Appendix C: Target Catalog

Metric	Target	Units
Porosity	< 1	%
Serial Sectioning	< 1	Void area/total area
Density Calculation	< 1	Actual mass/calculated mass
Fill Volume		
Small Cube	10/10000	Inch
Large Cube	10/10000	Inch
Cylinder	10/10000	Inch
Allowable Fluid Volume	400	%
Working Pressure	>29	mmHg
Total Pot Life	90	minutes
Lattice Fill Time	Unknown	Minutes
Degas Time	Unknown	Minutes
Total Working Time	<90	Minutes





References

Flater, P. (2017). Senior Design Project Definition [PDF]. Retrieved from FAMU-FSU College of Engineering Senior Design Blackboard site.

Do I have to vacuum de-gas the silicone rubber? Is vacuuming the rubber that important? (n.d.). Retrieved November 02, 2017, from <https://www.smooth-on.com/support/faq/111/>

Dow Corning. (April 2004). Sylgard 184 Silicone Elastomer. [Material Safety Data Sheet]. Retrieved November 02, 2017, from <http://www.dowcorning.com/DataFiles/090276fe80190b08.pdf>